

CANTILEVER MOUNT SPINDLE MODELS

DTS 1300

The DTS 1300 is the most compact of the DTS spindles and will fit on grinders with severe space constraints. The DTS 1300 is a cantilever mount spindle that is intended primarily for tracing forms into grinding wheels. Although compact, the DTS 1300 is still rigid and powerful enough to handle superabrasive applications. This model is intended to accommodate diamond rolls up to 4 inches (100 mm) in diameter and ½ inch (13 mm) wide.

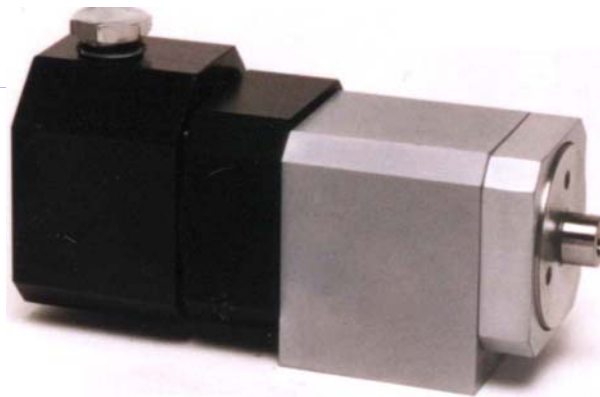
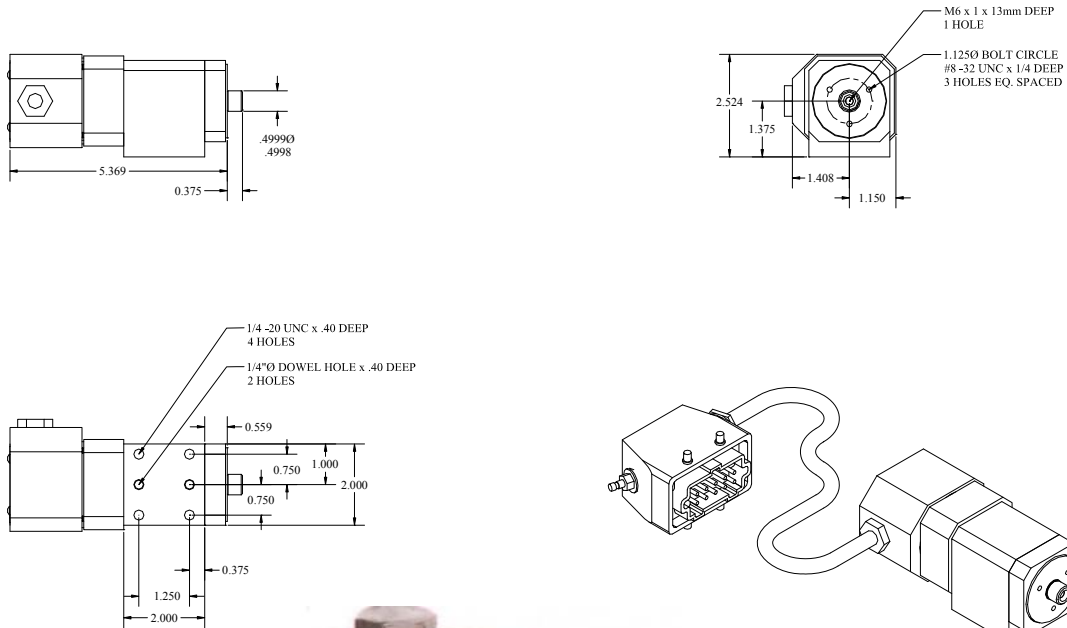

G II Solutions, Inc.
201 Bank Street
P.O. Box 428
Central, SC 29630

Phone: 864.639.6605
Fax: 864.639.4056
E-mail: info@giisolutions.com
Web Site: www.giisolutions.com